

1 Plan A-A  
0490

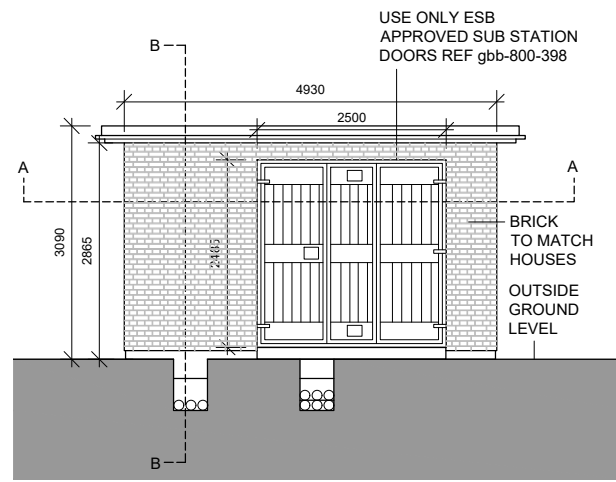

2 Front Elevation  
0490

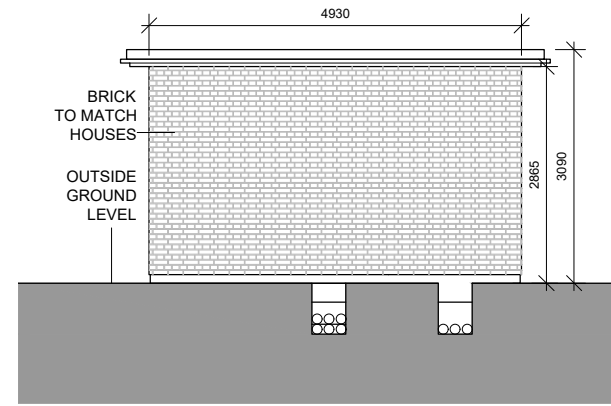

3 Rear Elevation  
0490

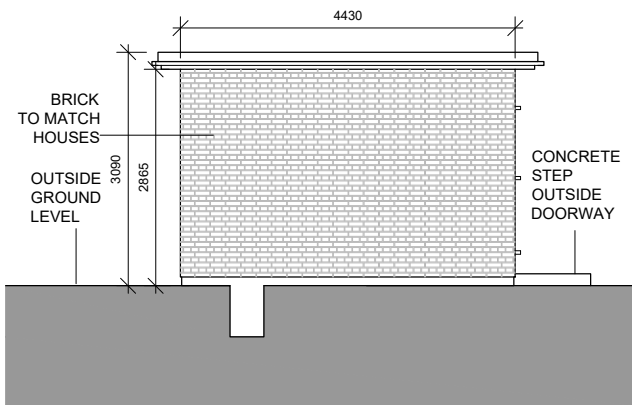

4 Side Elevation 1  
0490

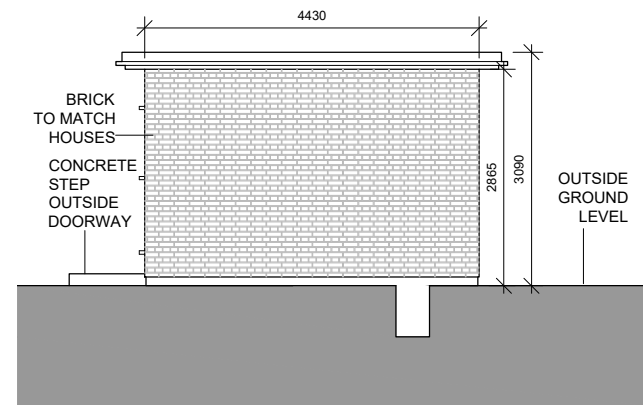

5 Side Elevation 2  
0490

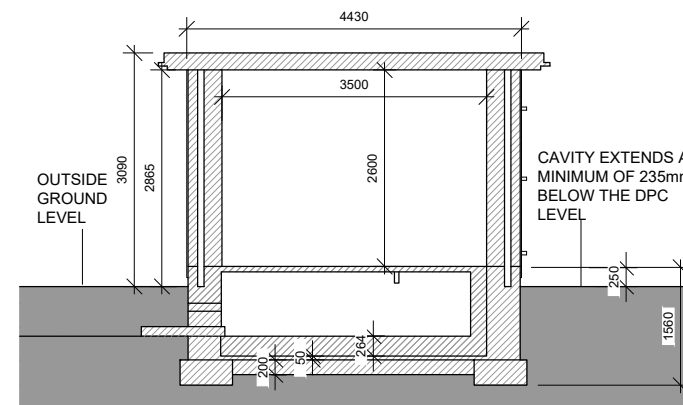

6 Section B-B  
0490

ESB SUB STATION LOCATION



1:2000 KEY PLAN

NOTES / LEGEND

NORTH POINTS AND LEVELS TO BE REFERENCED FROM SITE PLAN  
REFER TO ENGINEER DRAWINGS FOR DETAILED DRAWINGS AND NOTES

Key Plan:

Rev: Date: Description: By:

Rev:	Date:	Description:	By:

**MOLA** 2 Dennybrook Road,  
Dennybrook,  
Dublin 4, Ireland  
Telephone +353 1 218 3800  
www.molaarchitecture.com

Notes  
Do not scale.  
Use figured dimensions only.  
This drawing is to be read in conjunction with all relevant specifications and drawings.  
All dimensions to be checked on site.  
In the event of any discrepancies between drawings, the contractor is to inform the Architect immediately.  
© COPYRIGHT This drawing or design may not be reproduced without permission

Stage: **PLANNING**

Client:	Calm Homes Properties Ltd.
Project:	Cookstown Road Enniskerry
Drawing:	ESB Sub Station - Plan, section & elevations
Date:	Feb 2021
Scale:	1:100 at A3
Sheet:	3
Int. Job No.:	19010
Drawing No.:	19010_MOLA_A00_00_DR_A_XX_A00_0490_S0
Status:	S0
Revision:	00